

### Components

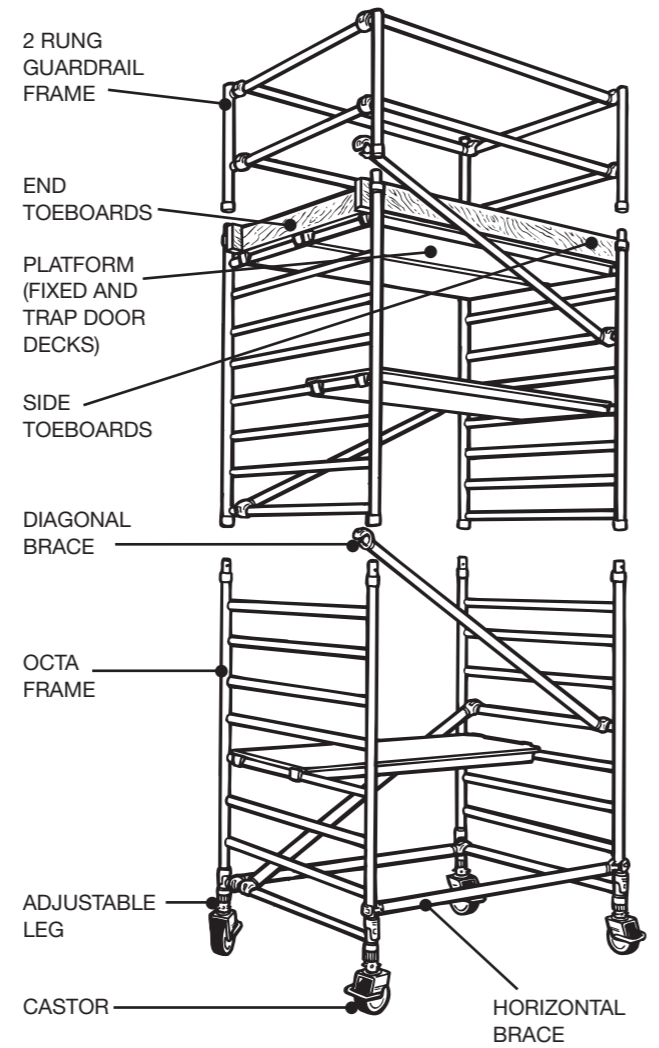

### CHECKLIST

- INSPECT COMPONENTS PRIOR TO ERECTION
- INSPECT TOWER PRIOR TO USE
- TOWER UPRIGHT
- CASTORS LOCKED/LEGS CORRECTLY ADJUSTED
- BRACES & PLATFORM LEVEL
- STABILISERS/OUTRIGGERS FITTED AS SPECIFIED
- PLATFORMS LOCATED & WINDLOCKS ON HANDRAILS IN PLACE
- TOEBOARDS LOCATED

REFER TO THIS CHECKLIST BEFORE USING EACH TIME

### Fitting Toeboards

Lock yellow plastic toeboard clips over rung and deck claw as shown. Position as (A) on right hand deck claw. On other side of working platform position as (B). Place 25mm thick toeboards into slots in toeboard clips as shown.

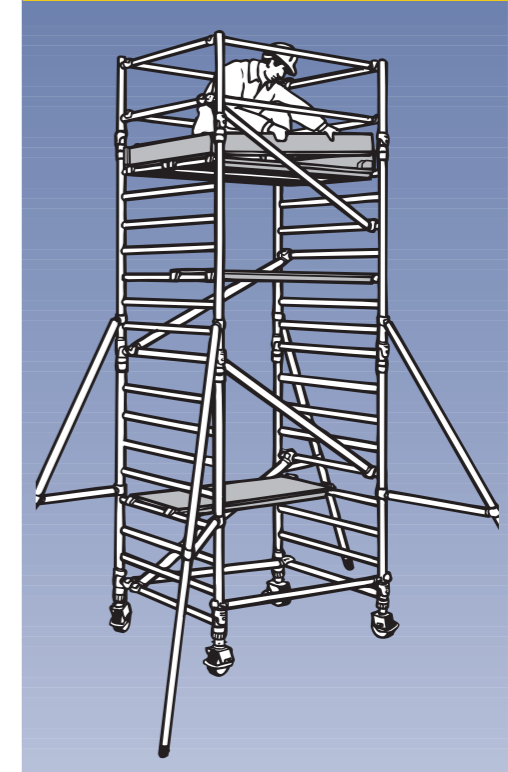

### Introduction

This BOSS CLIMA User Guide is designed to provide you with step by step instructions to ensure that your system is erected with the maximum of ease and safety. Before assembly, please read the safety notes carefully. Operatives must be qualified or competent to erect the tower. If the tower is passed on to another person they should also receive these instructions. Erect the tower in the position required. For full information on the application and use of a Mobile Access and Working Tower consult the PASMA Guide or prEN 1298.



**SGB Youngman**  
All enquiries  
**08700 130360**

email: [info@sgb.co.uk](mailto:info@sgb.co.uk)  
[www.sgb.co.uk](http://www.sgb.co.uk)

SGB Youngman,  
The Causeway, Maldon, Essex, CM9 4LJ, England.

## QUANTITY SCHEDULE

### BOSS 1450 CLIMA FRAME TO HD1004: AVAILABLE IN 3 LENGTHS – 1.8m, 2.5m & 3.2m

#### INTERNAL/EXTERNAL USE

DESCRIPTION	WORKING HEIGHT PLATFORM HEIGHT		INTERNAL USE ONLY																			
	4.2m 2.2m	4.7m 2.7m	5.2m 3.2m	5.7m 3.7m	6.2m 4.2m	6.7m 4.7m	7.2m 5.2m	7.7m 5.7m	8.2m 6.2m	8.7m 6.7m	9.2m 7.2m	9.7m 7.7m	10.2m 8.2m	10.7m 8.7m	11.2m 9.2m	11.7m 10.2m	12.2m 10.7m	12.7m 11.2m	13.2m 11.7m	13.7m 12.2m	14.2m 12.2m	
1.25/150/200mm CASTOR	4	4	4	4	4	4	4	4	4	4	4	4	4	4	4	4	4	4	4	4	4	4
250mm ADJUSTABLE LEG	4	4	4	4	4	4	4	4	4	4	4	4	4	4	4	4	4	4	4	4	4	4
1450 2 RUNG GUARDRAIL FRAME	2	2	2	2	2	2	2	2	2	2	2	2	2	2	2	2	2	2	2	2	2	2
1450 6 RUNG CLIMBING FRAME	2	2	2	2	2	2	2	2	2	2	2	2	2	2	2	2	2	2	2	2	2	2
1450 8 RUNG CLIMBING FRAME	2	2	4	2	4	2	4	2	4	6	4	6	4	6	6	8	6	8	10	8	10	12
1.8/2.5/3.2m FIXED DECK	1	1	1	1	1	1	1	1	1	2	2	2	2	2	2	2	2	2	2	2	2	2
1.8/2.5/3.2m TRAP DOOR DECK	1	1	2	2	2	2	2	2	2	2	2	2	2	2	2	2	2	2	2	2	2	2
1.8/2.5/3.2m HORIZONTAL BRACE (RED)	6	6	8	8	8	10	10	10	10	10	10	10	10	10	10	10	10	10	10	10	10	10
2.1/2.7/3.4m DIAGONAL BRACE (BLUE)	2	3	3	4	4	5	6	6	7	7	8	8	8	9	10	10	10	11	11	11	12	12
1.8/2.5/3.2m SIDE TOEBOARD	2	2	2	2	2	2	2	2	2	2	2	2	2	2	2	2	2	2	2	2	2	2
1.2m END TOEBOARD	2	2	2	2	2	2	2	2	2	2	2	2	2	2	2	2	2	2	2	2	2	2
TOEBOARD HOLDER	4	4	4	4	4	4	4	4	4	4	4	4	4	4	4	4	4	4	4	4	4	4

SP7 FIXED STABILISER	4	4	4	4	4	4	4	4	4	4	4	4	4	4	4	4	4	4	4	4	4	4
SP10 TELESCOPIC STABILISER																						

TOTAL TOWER SELF-WEIGHT (KGS) 1.8m	99	110	167	175	176	204	208	216	217	228	230	239	257	268	272	279	281	291	294	300	303	303
TOTAL TOWER SELF-WEIGHT (KGS) 2.5m	115	127	154	162	162	234	237	244	247	259	262	270	294	306	302	318	319	329	332	339	342	342
TOTAL TOWER SELF-WEIGHT (KGS) 3.2m	136	147	183	192	193	236	239	246	249	297	300	310	341	354	349	366	367	378	381	388	391	391

#### NUMBER OF WORKING PLATFORMS ALLOWED

The number of working levels is based on fully loading each single deck to the maximum of 275kg. A deck is defined as a single unit, but a working platform can be either one or two decks. The 275kg limit applies to each such working level, regardless of the number of decks.

In normal circumstances only two such working levels are permissible, as with the taller structures/lengths self-weight will be a limiting factor.

Maximum Safe Working Load for the tower structure is 950kg.

Should heavier loads than these be required for particular applications, your local Branch will be able to provide guidance.

The quantities above comply with the requirements of the Construction (Health, Safety & Welfare) Regulations 1996 and BS 1139 Part 3 (HD 1004). They include double handrailing to the rest platform level, and toeboards will need to be added if this is used as a working platform.

Fixed platforms are provided every 4m (Per BS 1139 p13), plus an additional platform to ease assembly. However this is not a Regulatory requirement.

Should a fully decked rest platform be employed two additional handrails will be required.

BALLAST: 1450 CLIMA FRAME – Internal/External use. There is no requirement for ballast on 1450 towers if using stabilisers as detailed in the above table. If for internal use only, SP10 stabilisers may be fitted up to 10.7m platform height.

#### MOBILE OUTRIGGERS

MP7 mobile outriggers can be used instead of SP10 and stabilisers, as detailed below.

MP7 mobile outrigger kits comprise:

MP7 MOBILE OUTRIGGER	4
125/150/200mm CASTOR	4
(Use same diameter castors as on tower)	
250mm ADJUSTABLE LEG	4

The above components replace:

SP7/SP10 STABILISER	4
---------------------	---

With Outriggers a 2m Plan Brace is also required.

#### STABILISERS

To improve rigidity, larger stabilisers can be used at a lower level than shown in the table.

### BOSS 850 CLIMA FRAME TO HD1004: AVAILABLE IN 3 LENGTHS – 1.8m, 2.5m & 3.2m

#### INTERNAL/EXTERNAL USE

DESCRIPTION	WORKING HEIGHT PLATFORM HEIGHT		INTERNAL USE ONLY																			
	4.2m 2.2m	4.7m 2.7m	5.2m 3.2m	5.7m 3.7m	6.2m 4.2m	6.7m 4.7m	7.2m 5.2m	7.7m 5.7m	8.2m 6.2m	8.7m 6.7m	9.2m 7.2m	9.7m 7.7m	10.2m 8.2m	10.7m 8.7m	11.2m 9.2m	11.7m 10.2m	12.2m 10.7m	12.7m 11.2m	13.2m 11.7m	13.7m 12.2m	14.2m 12.2m	
125/150/200mm CASTOR	4	4	4	4	4	4	4	4	4	4	4	4	4	4	4	4	4	4	4	4	4	4
250mm ADJUSTABLE LEG	4	4	4	4	4	4	4	4	4	4	4	4	4	4	4	4	4	4	4	4	4	4
850 2 RUNG GUARDRAIL FRAME	2	2	2	2	2	2	2	2	2	2	2	2	2	2	2	2	2	2	2	2	2	2
850 6 RUNG CLIMBING FRAME	2	2	4	2	4	2	4	6	4	6	6	8	8	8	10	8	10	10	10	12	10	12
1.8/2.5/3.2m TRAP DOOR DECK	1	1	2	2	2	3	3	3	3	3	3	4	4	4	4	4	4	4	4	4	4	4
1.8/2.5/3.2m HORIZONTAL BRACE (RED)	6	6	10	10	10	14	14	14	14	14	14	14	18	18	18	18	18	18	18	18	18	18
2.1/2.7/3.4m DIAGONAL BRACE (BLUE)	2	3	3	4	4	5	6	6	7	7	8	8	9	9	10	10	10	11	11	11	12	12
1.8/2.5/3.2m SIDE TOEBOARD	2	2	2	2	2	2	2	2	2	2	2	2	2	2	2	2	2	2	2	2	2	2
0.6m END TOEBOARD	2	2	2	2	2	2	2	2	2	2	2	2	2	2	2	2	2	2	2	2	2	2
TOEBOARD HOLDER	4	4	4	4	4	4	4	4	4	4	4	4	4	4	4	4	4	4	4	4	4	4

SP7 FIXED STABILISER	4	4	4	4	4	4	4	4	4	4	4	4	4	4	4	4	4	4	4	4	4	4
SP10 TELESCOPIC STABILISER																						
SP15 TELESCOPIC STABILISER																						

BALLAST REQUIRED (KGS) 2.5m																						
BALLAST REQUIRED (KGS) 3.2m																						

TOTAL TOWER SELF-WEIGHT (KGS) 1.8m	97	106	163	171	172	198	202	209	211	219	222	231	250	258	262	269	271	279	282	288	291	291
TOTAL TOWER SELF-WEIGHT (KGS) 2.5m	113	122	150	158	159	228	231	237	241	250	254	262	287	296	292	307	309	317	321	327	331	331
TOTAL TOWER SELF-WEIGHT (KGS) 3.2m	134	143	179	188	189	229	234	240	243	289	292	302	334	343	340	356	357	366	369	376	376	380

#### NUMBER OF WORKING PLATFORMS ALLOWED

The number of working levels is based on fully loading each single deck to the maximum of 275kg.

A working platform can be either one or two decks, and the 275kg applies to each working level, regardless of whether one or two decks.

The number of working levels will be limited by the total Safe Working Load of the tower.

The Maximum Safe Working Load for the tower structures shown above is 950kg. For heights in excess of these, and for heavier loads, consult your local Branch for guidance.

The quantities above comply with the requirements of the Construction (Health, Safety & Welfare) Regulations 1996 and BS 1139 Part 3 (HD 1004). They include double handrailing to the rest platform level, and toeboards will need to be added if this is used as a working platform.

Fixed platforms are provided every 4m (Per BS 1139 p13), plus an additional platform to ease assembly. However this is not a Regulatory requirement.

Should a fully decked rest platform be employed two additional handrails will be required.

#### STABILISERS AND BALLAST: – Internal/External use.

Stabiliser requirements are based on calculations from HD1004:

- Up to 8.2m (Platform Height) the stabilisers and ballast are shown for external use.
- Above 8.2m, the shedule is for internal use only.

For internal use only, towers may be erected up to 12.5m without ballast, and SP10 stabilisers may be fitted up to 9.7m platform height. For greater rigidity, fit SP15 at lower height.

#### MOBILE OUTRIGGERS

MP7 and MP16 mobile outriggers can be used instead of SP10 and SP15 telescopic stabilisers respectively, as detailed below.

MP7 and MP16 mobile outrigger kits comprise:

MP7/MP16 MOBILE OUTRIGGER	4
125/150/200mm CASTOR	4
(Use same diameter castors as on tower)	
250mm ADJUSTABLE LEG	4

The above components replace:

SP7/SP10/SP15 TELESCOPIC STABILISER	4
-------------------------------------	---

With Outriggers a 1.5m Plan Brace is also required.

# BOSS™

## 1450/850 CLIMA ALLOY ACCESS SYSTEM

### ASSEMBLY GUIDE

- 1** Check that interlock clips are disengaged on all frames.

#### INTERLOCK CLIP

TO LOCK

TO RELEASE

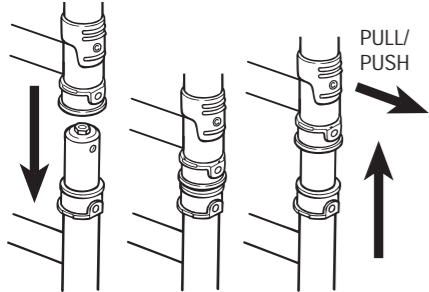

- 7** Clip on third diagonal braces (blue) as shown. Ensure that separate frames are always braced together. Locate Trapdoor Deck on top of lower frame (8th rung) ensuring trap opens to outside of tower.



- 2** Insert four adjustable leg/castor assemblies into two frames. Lock castors. Base plates can be fitted to adjustable leg if tower is static. We recommend that two persons are required, to ease the erection process. Push castor onto adjustable leg to secure.

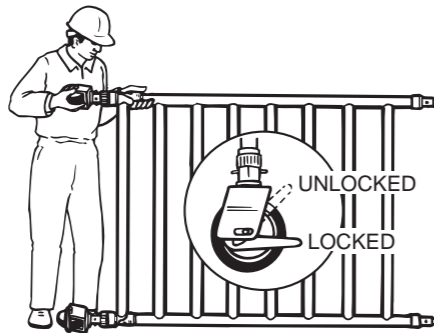

- 3** Clip horizontal brace (Red) onto side of one frame. Frame will now be self supporting.

**Note:** All locking claws should be primed before use by pulling back trigger. After dismantling – ensure locking mechanism is released.

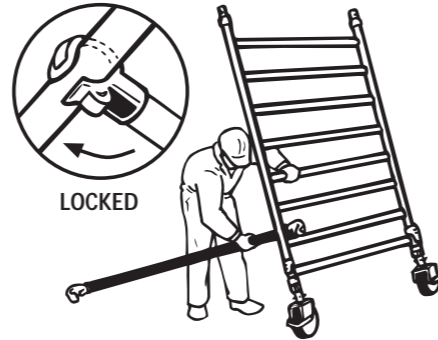

- 4** Clip other end of horizontal brace onto other frame. Clip second horizontal brace onto other side of frames. Ensure claws are locked outwards **never** inwards. Lock castors.



- 5** Clip first diagonal braces (blue) as shown. Adjust legs to ensure tower is vertical and square and that horizontal braces are level, using a spirit level.



- 6** Position fixed deck on fourth rung of frames as shown. Position second lift of frames and engage interlock clips. Add temporary guardrails and clip second diagonal brace (blue) as shown.

**Note:** If erecting more than one lift, fit appropriate stabilisers or outriggers **now**. (See special note on stabilisers & outriggers).



- 8** Locate further Trapdoor Deck on 4th Rung of upper Frame, (opposite side of tower) and engage windlocks. Add temporary horizontal handrails.

**Note:** Add Trapdoor Deck rest platform every 4m, with horizontal braces at 0.5m and 1.0m rung levels on the outside face. If it is a working level, add toeboards. For fully decked areas, add 2 horizontal braces to the other face.

**Note:** always climb inside the tower.



- 9** Move temporary horizontal handrails to either side of Frame. Position 2 Rung Guardrail Frames. Engage interlock clips.

Clip two horizontal braces (red) to each side of the Guardrail Frame. Return to platform on 8th Rung (see 8) and move uppermost Trapdoor Deck to 8th rung of upper frame. Ensure trap opens to outside of tower. Clip diagonal braces (blue) to lock Guardrail Frames to Frame below.

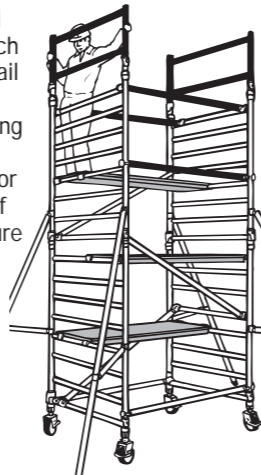

- 10** Move temporary horizontal handrail braces once Guardrail Frame horizontal braces are in place, to lower platform.

Move Fixed Deck from 4th rung of first frame and re-locate on top working platform alongside Trapdoor Deck. Engage windlocks. Fit toeboards now, (see instructions on reverse). Ensure platform on 8th rung is Guardrailed. To dismantle the structure, reverse steps 10 – 2.

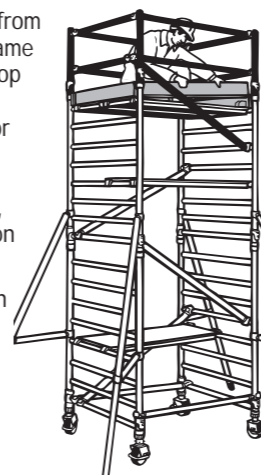

- 11 Tower finishing with 6 rung frames** Position 6 rung frames. Engage interlock clips. Clip 2 horizontal handrail braces (red) to each side of tower. (See note 10). Clip on diagonal braces (blue) as shown. Place fixed and trapdoor decks on 2nd rungs of 6 rung frames, ensuring that the trapdoor is positioned over ladder and opens to outside of tower.

**Fit toeboards now (see instructions on reverse). Rest Platform (every 4m), omitted for clarity.**

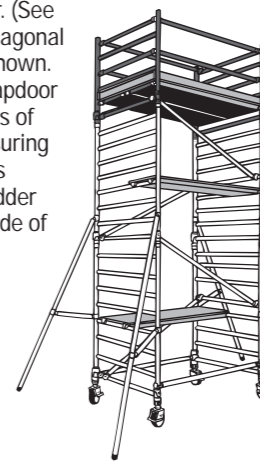

- 12 Tower finishing with 8 rung frames** Position 8 rung frames. Engage interlock clips. Clip 2 horizontal handrail braces (red) to each side of tower. (See note 10). Clip on diagonal braces (blue) as shown. Place fixed and trapdoor decks on 4th rungs of 8 rung frames, ensuring that the trapdoor is positioned over ladder and opens to the outside of tower.

**Fit toeboards now (see instructions on reverse).**

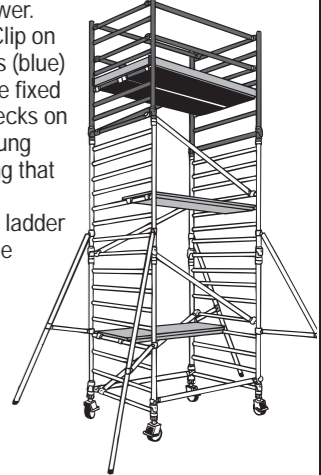

## STABILITY: STABILISERS

Attach one stabiliser to each corner of tower at approx. 45 degrees. If handle on clamp is obstructed from tightening, undo and place handle on other side of clamp.

Ensure top clamp is positioned immediately under frame rungs and tighten using the handle just enough to hold clamp in position. The bottom clamp should be positioned as low down as possible (see diagram). With SP15 position mid clamp and lightly tighten.

Extend telescopic legs until rubber foot is in contact with ground. Lock telescopic leg with interlock clip. If Plan Bracing is desired clip braces (Green) from tower to stabilisers at each end of tower as shown. Ensure rubber feet are in firm contact with the ground by sliding lower clamp downwards and tighten securely.

Securely tighten top clamp (and mid clamp on SP15's) to provide a rigid base structure.

When moving tower lock each telescopic leg just clear of the ground, unlock castors ensuring area is firm and clear of all obstructions both on the ground and above. After moving check all castors are firmly on the ground and locked, and that the tower is vertical. Re-position stabilisers as above.

### SP7



### SP10 (Optional Plan Brace Shown)

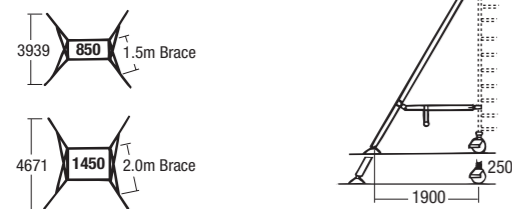

### SP15 (Optional Plan Brace Shown)

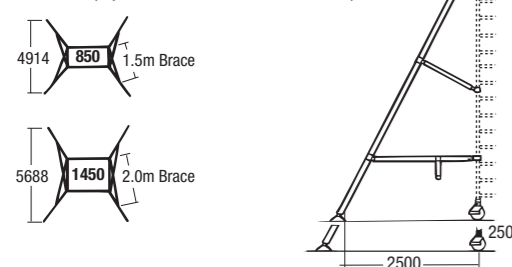

## MOBILE OUTRIGGERS

Insert adjustable leg/castor assemblies into leg of each outrigger, lock castors.

Attach one outrigger to each corner of the tower at approx. 45 degrees.

If handle on clamp is obstructed from tightening, undo and place handle on other side of clamp. Ensure top clamp is positioned immediately under frame rung and tighten using handle just enough to hold clamp in position. After adjusting legs until castors are firmly on the ground, carry out this procedure on lower clamp.

Clip in plan braces from tower to outriggers at each end of tower as shown. Securely tighten all clamps and double check that all castors are firmly in contact with the ground and are locked.

When moving tower unlock all castors, ensure area is firm and clear of all obstructions both on the ground and above the tower. After moving ensure tower is vertical and that all castors are firmly on the ground and locked.

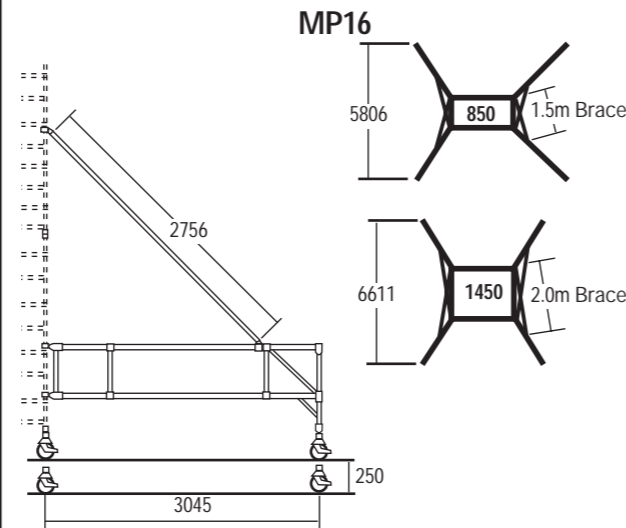
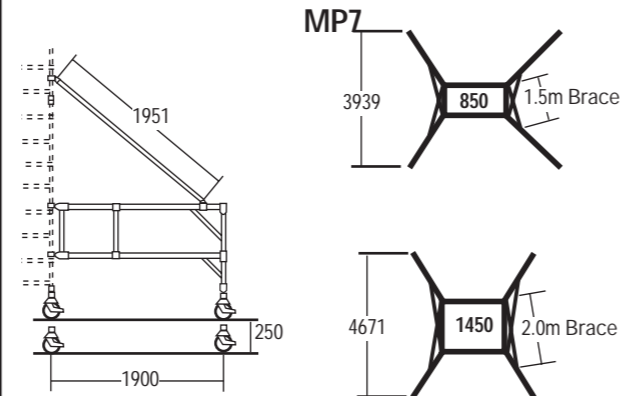

## USAGE ADVICE

### ERECTION

- Check that all components are on site and that they are functioning correctly – See Quantity Schedule.
- Check if the ground on which the mobile access tower is to be erected and moved, is capable of supporting the tower.
- During the erection of a tower it is recommended that a temporary guardrail brace be employed.
- The safe working load is 275 kgs (606 lbs) uniformly distributed – maximum concentrated load 150 kgs (330 lbs) per deck up to a maximum of 950 kgs (2100 lbs) per tower (including self weight). **This must not be exceeded.**
- Towers **must** always be climbed from the inside during assembly and using the built-in ladder provided during use.
- Do not use boxes or step ladders on the platform to gain additional height.

### LIFTING OF EQUIPMENT

- Tower components should be firmly secured by a reliable lifting material (eg rope), employing a reliable Knot (eg clove hitch), to ensure safe fastening.



### STABILISERS/BALLAST

- Stabilisers or outriggers and ballast weights shall always be fitted when specified.
- Ballast is used at the base to stabilise towers against overturning. The QUANTITY SCHEDULE shows the recommended stabilisation. In circumstances where there is restricted ground clearance for stabilisers/outriggers, contact your supplier for advice.

It must be of solid materials (i.e. not water or loose sand) and should not be positioned to overload individual legs. Ballast should be secured against accidental removal, and be supported on the lowest rung of the bottom frame.

### MOVEMENT

- The tower should only be moved by manual effort, and only from the base.
- When moving the tower, beware of live electrical apparatus, particularly overhead, plus wires or moving parts of machinery.
- No personnel or materials should be on the tower during movement.
- Caution should be exercised when wheeling a tower over rough, uneven or sloping ground, taking care to unlock and lock castors. If stabilisers are fitted, they should only be lifted sufficiently above the ground to clear ground obstructions. The height of the tower, when being moved, should not exceed 2.5 times the minimum base dimensions, or 6 metres overall height.

### DURING USE

- Beware of high winds in exposed, gusty or medium breeze conditions. We recommend that in wind speeds over 7.7 metres per second (17 m.p.h.), cease working on the tower. If the wind becomes a strong breeze, expected to reach 11.3 metres per second (25 m.p.h.), tie the tower to a rigid structure. If the wind is likely to reach gale force, over 18 metres per second (40 m.p.h.), the tower should be dismantled.

Wind Description	Beaufort Scale	Beaufort No.	Speed in m.p.h.	Speed in m/sec.
Medium Breeze	Raises dust and loose paper, twigs snap off.	4	8-12	4-6
Strong Breeze	Large branches in motion, telegraph wires whistle.	6	25-31	11-14
Gale Force	Walking is difficult.	8	39-46	17-21

Beware of open ended buildings which can cause funneling effect.

- Do not abuse equipment. Damaged or incorrect components should never be used.
- Raising and lowering components, tools, and/or materials by rope should be conducted within the tower base. Ensure that the safe working load of the supporting decks and the tower structure is not exceeded.
- The assembled tower is a working platform and should not be used as a means of access to other structures.
- Beware of horizontal forces (eg power tools) which could generate instability. Maximum horizontal force 20 kg.
- The stairway towers featuring an inclined staircase access are for use with personnel frequently carrying tools and/or materials.
- Mobile towers are not designed to be suspended - please refer to your supplier.

### TIES

- Ties should be used when the tower goes beyond its safe height beyond the limits of the stabilisers/outriggers or there is a danger of instability. They should be rigid, two way ties fastened to both uprights of the frame with load-bearing right angled or swivel couplers. Only couplers suitable for the 50.8mm dia. tube of the tower should be used. Ideally ties should secure to either face of a solid structure or by means of anchorages.
- The tie frequency may vary depending on the application, but they should, at a minimum, be at every 4 metres height.

### MAINTENANCE

- All components and their parts should be regularly inspected to identify damage, particularly to welds. Lost or broken parts should be replaced, and any tubing with indentations greater than 5mm should be put to one side for manufacture repair. Adjustable leg threads should be cleaned and lightly lubricated to keep them free running.