

**MiniMax Pack Details**

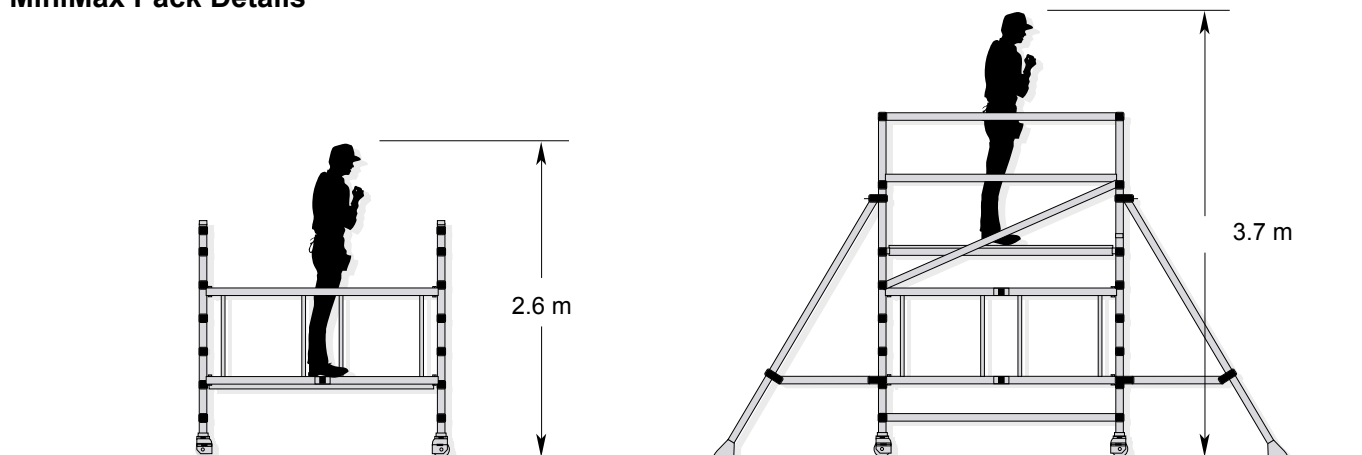

Safe Working Height 2.60m  
Platform Height 0.60m  
Base Pack

Safe Working Height 3.70m  
Platform Height 1.70m  
Base Pack + Guardrails + 2 x Small Stabiliser Packs

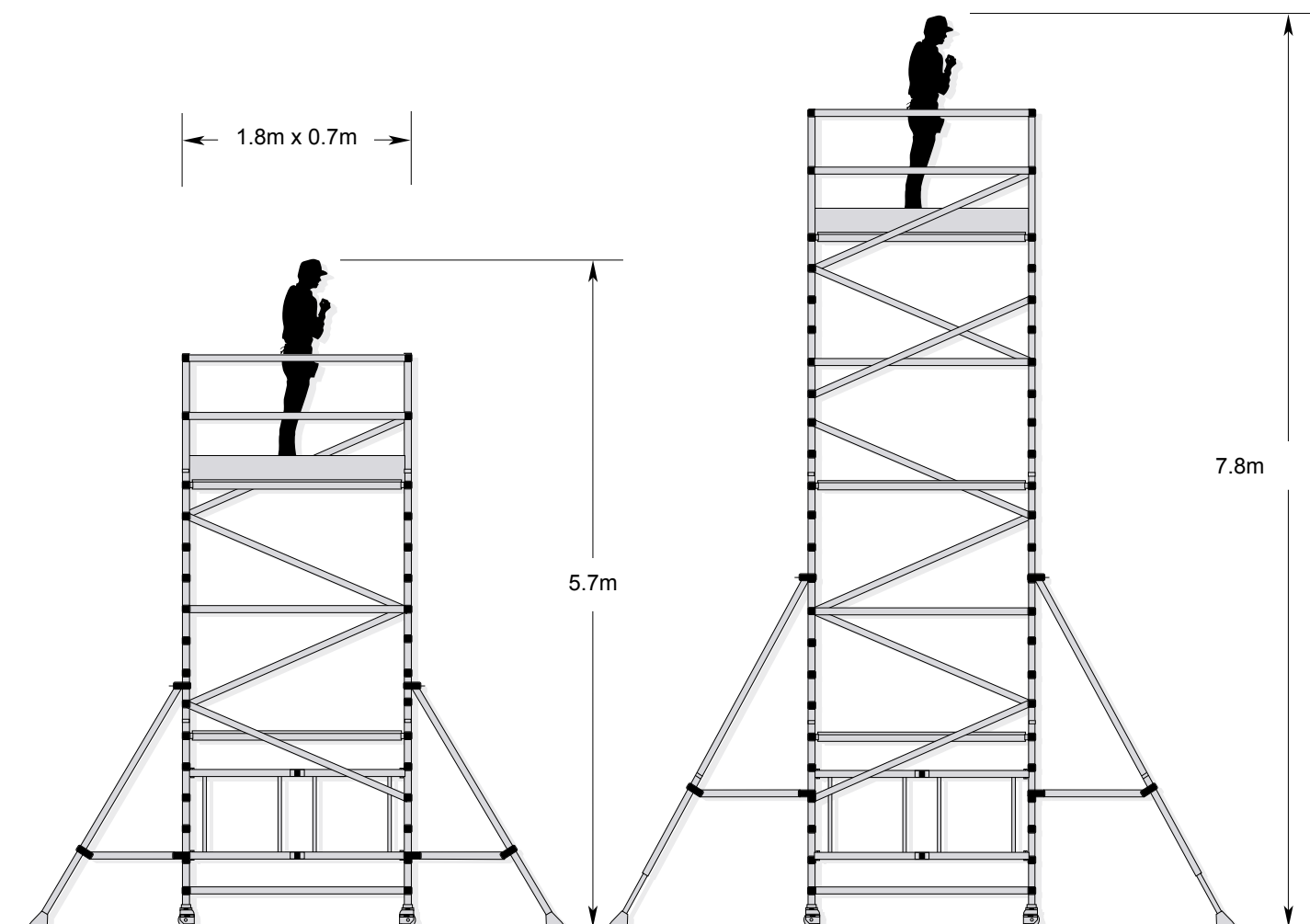

Safe Working Height 5.70m  
Platform Height 3.70m  
Base Pack + Guardrail Pack + Extension Pack  
+ 2 x Small Stabiliser Packs

Safe Working Height 7.80m  
Platform Height 5.80m  
Base Pack + Guardrail Pack + 2 x Extension Packs  
+ 2 x Medium Stabiliser Packs

**MiniMax Component Technical Details (Dimensions are in millimetres)**

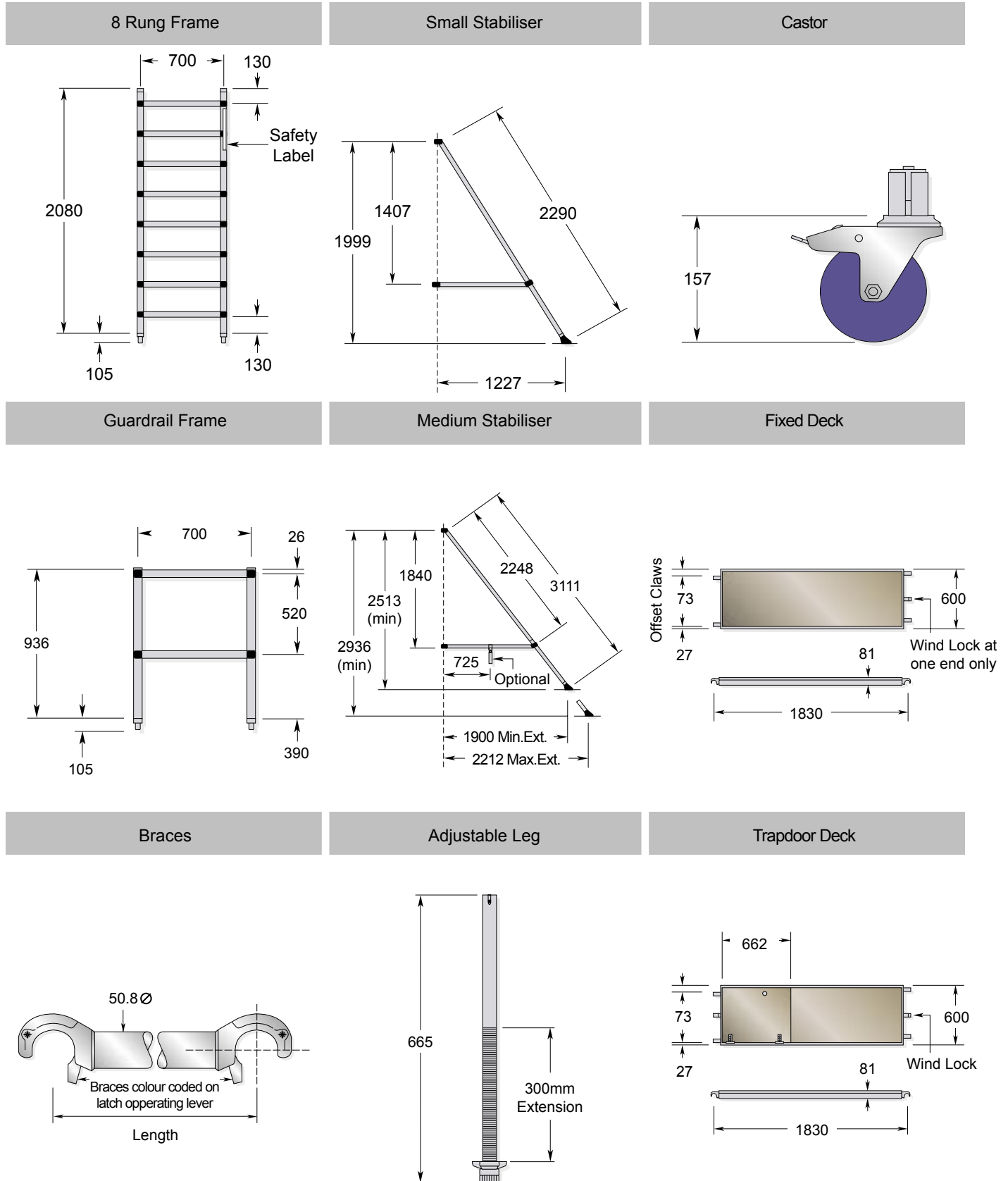

| Order Code | Component Name                   | Weight (kg) |
|------------|----------------------------------|-------------|
| 370518     | Base Pack                        | 34.0        |
| 378518     | Base Unit                        | 7.5         |
| 372518     | Guardrail Pack                   | 15.6        |
| 371518     | Extension Pack                   | 44.1        |
| 373518     | Small Stabiliser Pack            | 11.6        |
| 374518     | Medium Stabiliser Pack           | 18.0        |
| 379518     | Adjustable Leg Pack              | 5.0         |
| 000622     | End Toeboard                     | 1.0         |
| 576917     | Side Toeboard                    | 2.3         |
| 000621     | 1.8m Horizontal Brace (handrail) | 1.2         |

# YOUNGMAN

INNOVATIVE WORK AT HEIGHT SOLUTIONS



## MiniMax

Mobile Aluminium Tower

USER GUIDE

## Introduction

This Assembly Guide is designed to provide you with step by step instructions to ensure that your system is erected with the maximum of ease and safety. Before assembly, please read the safety notes. Operatives must be qualified or competent to erect the tower. If the scaffold is passed on to another person they should also receive these instructions. Consult the PASMA Guide for full information on the use of Mobile Towers.



## Checklist

- Inspect components prior to erection
- Inspect tower prior to use
- Tower upright
- Castors locked and legs correctly adjusted
- Braces & platform level
- Stabilisers fitted as specified
- Platforms located & windlocks on
- Handrails in place
- Toeboards located
- Refer to this checklist before using each time.

## Safe Use

- Check that all components are on site and that they are functioning correctly – (refer to check list and quantities).
- Check that the ground is level and capable of supporting the weight of the structure.
- During erection it is recommended that a temporary guardrail brace be employed.
- The safe working load is 220 kgs per platform uniformly distributed, 500kg per tower structure.

**This must not be exceeded.**

- The tower should always be climbed from the inside.
- Do not use boxes or step ladders on the platform to gain additional height.

## Lifting of Equipment

- Components should be firmly secured by a reliable lifting material (eg rope), employing a reliable knot to ensure safe fastening and always lift within the tower.

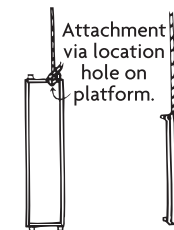

- 
- 
- 
- 
- 
- 
- 
- 
- 
-

# Safety First

## Stabilisers/Ballast

- All 4 stabilisers must be fitted when specified.
- When using the 1.7m tower externally, 4 small stabilisers must be fitted.
- In circumstances where there are ground restrictions for stabilisers to be positioned as specified, ballast may be required, contact your supplier for advice.

## Movement

- The tower should only be moved by manual effort, and only from the base.
- When moving the tower, beware of live electrical apparatus, particularly overhead, plus wires or moving parts of machinery.
- No person or materials should be on the tower during movement.
- Caution should be exercised when wheeling a tower over rough, uneven or sloping ground, taking care to unlock and lock castors.
- The height of the tower, when being moved, should not exceed 3.7 metres. Max free standing height 5.8 metres.

## During Use

- Beware of high winds in exposed, gusty or medium breeze conditions. We recommend that in wind speeds over 7.7 metres per second (17 m.p.h.), cease working on the tower. If the wind becomes a strong breeze, expected to reach 11.3 metres per second (25 m.p.h.), tie the tower to a rigid structure. If the wind is likely to reach gale force, over 18 metres per second (40 m.p.h.), the tower should be dismantled.

# Safety First

| Wind Description | Beaufort Scale                                    | Beaufort No. | Speed in m.p.h | Speed in m/sec |
|------------------|---|--------------|----------------|----------------|
| Medium Breeze    | Raises dust and loose paper, twigs snap off       | 4            | 8-12           | 4-6            |
| Strong Breeze    | Large branches in motion, telegraph wires whistle | 6            | 25-31          | 11-14          |
| Gale Force       | Walking is difficult                              | 8            | 39-46          | 17-21          |

- Beware of open ended buildings, which can cause funnelling effect.
- Do not abuse equipment. Damaged or incorrect components should never be used.
- The assembled tower is a working platform and should not be used as a means of access to other structures.
- Beware of horizontal forces (eg power tools) which could generate instability. Maximum horizontal force 20 kg.

## Ties

- When ties are required, they should be rigid (ie solid tube and couplers).
- Always tie to a solid structure.
- The tie frequency should be at every 4m intervals vertically.

## Maintenance

- All components and their parts should be regularly inspected to identify damage, particularly to welds. Lost or broken parts should be replaced, and any tubing with indentation greater than 5mm should not be used. Adjustable leg threads should be cleaned and lightly lubricated to keep them free running.

# Components

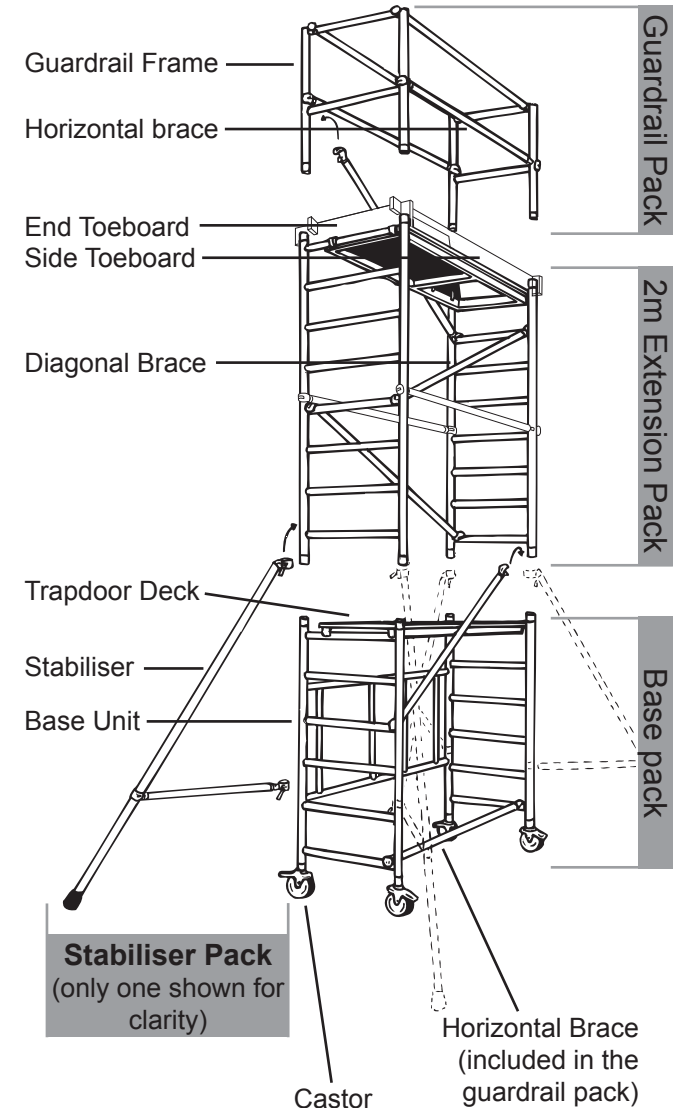

# Quantity Schedule

## Quantity Schedule in Packs

Mini-Max Tower to HD1004: 1.83m platform Length

Internal/External Use

|                     |      |      |      |      |
|---------------------|------|------|------|------|
| Working Height (m)  | 2.8m | 3.7m | 5.7m | 7.8m |
| Platform Height (m) | 0.9m | 1.7m | 3.7m | 5.8m |

| Description             | Weight (KG) | Pack Quantities |   |   |   |
|-------------------------|-------------|-----------------|---|---|---|
| Base Pack               | 34          | 1               | 1 | 1 | 1 |
| Guardrail Pack          | 16          |                 | 1 | 1 | 1 |
| 2m Extension Pack       | 44          |                 |   | 1 | 2 |
| Small Stabiliser Pack*  | 12          |                 | 2 | 2 |   |
| Medium Stabiliser Pack* | 09          |                 |   | 2 |   |

\* 4 Stabilisers required in total.

## Quantity Schedule in Components

Mini-Max Tower to HD1004: 1.83m platform Length

Internal/External Use

|                     |      |      |      |      |
|---------------------|------|------|------|------|
| Working Height (m)  | 2.8m | 3.7m | 5.7m | 7.8m |
| Platform Height (m) | 0.9m | 1.7m | 3.7m | 5.8m |

| Description             | Component Quantities |    |   |   |
|-------------------------|----------------------|----|---|---|
| Folding Base Frame      | 1                    | 1  | 1 | 1 |
| Trapdoor Platform       | 1                    | 1  | 2 | 3 |
| 8 Rung Frames           |                      |    | 2 | 4 |
| Diagonal Braces         |                      | 1  | 4 | 7 |
| Horizontal Braces       |                      | 5  | 7 | 9 |
| Toeboard Kit            |                      | 1  | 1 |   |
| Guardrail Frames        |                      | 2  | 2 | 2 |
| Small Stabilisers (SP7) |                      | 4* | 4 |   |
| Medium Stabiliser Pack* |                      |    |   | 4 |

\* Only required for external use.

# Assembly

## Stage 1: Base Pack

**1** Move the Base Unit into required position. Unfold Base Frame.

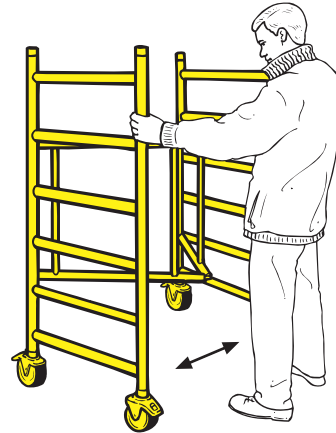

**2** Push folding frame outwards until folding elbow joints lock into position. Fully unfold base frame. Ensure both folding elbow joints are in locked position (see insert). To unlock joint press latch inwards.

**Lock brake on castors, ensure castors always face**

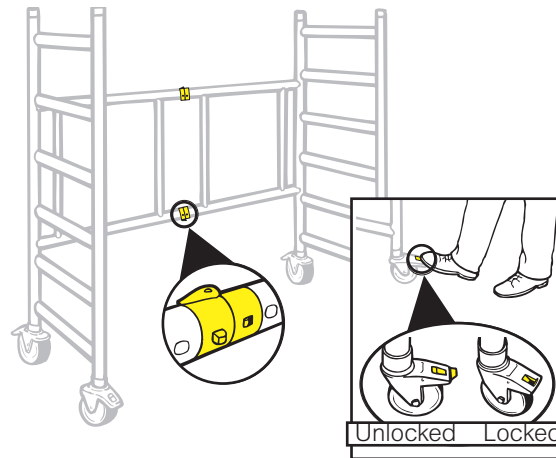

# Assembly

**3** Position platform at desired height level. **Do not position platform above 3rd rung.** Ensure windlock is locked in position and Trapdoor Platform is level before ascending platform.

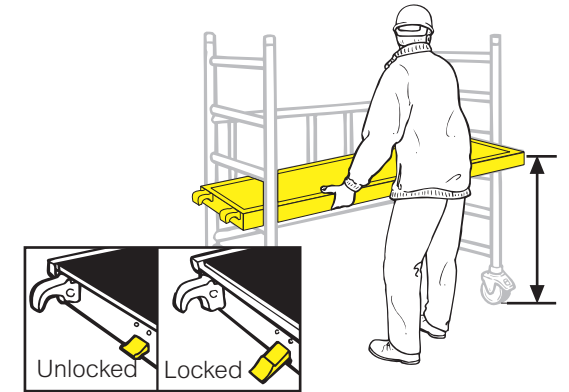

**4** Base Frame assembly is now complete. Always climb from the inside of the frame – never the outside. When working on platform never over-reach. **End Frames should be used to provide a firm hand hold.**

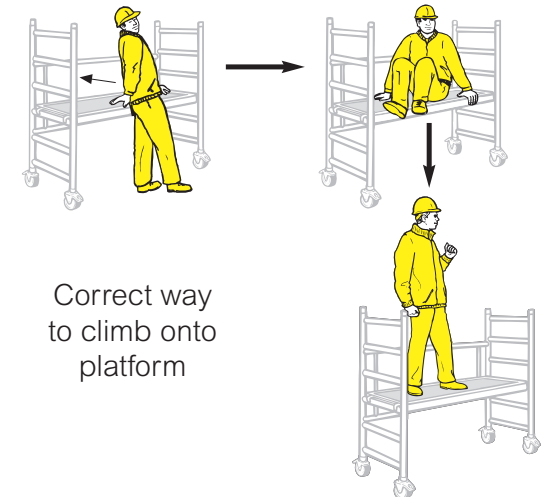

# Assembly

**From this stage on you will require the guardrail pack for platform heights up to 1.7m**  
1.7m platform height with added guardrails



## Stage 2: Base Pack, 2m Extension Pack & Guardrail Pack (for heights up to 3.7m)

**CHECK NOW if ground is uneven fit adjustable legs.**

**5** Fitting Adjustable Legs  
Turn Base Unit upside down so wheels are facing upwards as shown. Use a 19mm AF spanner to loosen bolt and remove fixed castor. Connect legs to castors. Insert adjustable legs into tubes, once complete reverse base frame with wheels being on floor. Adjust legs to produce a level structure. We recommend that two persons are required, to ease the erection process.

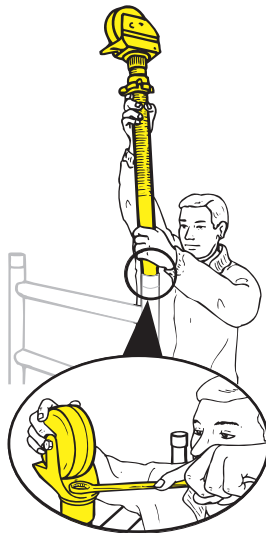

# Assembly

**6** Follow the Base Unit procedure, place Horizontal Brace on bottom rung. Ensure structure is level before tower system. Use adjustable legs to level. Now fit Spring Interlock clips (supplied in Guardrail Pack). Assemble the 4 spring locking clips as shown, expand spring over end and slide down into hole of tube.

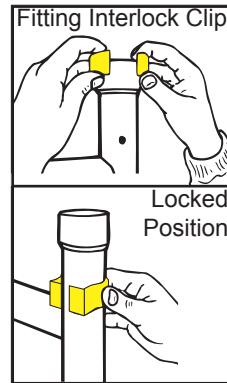

**7** Insert 2 m (8 rung) Lift Frame in Base Frame, ensure the interlock clips are engaged.

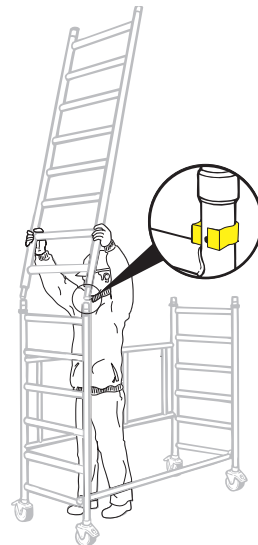

# Assembly

**8** Clip on diagonal braces as shown. Ensure that separate frames are always braced together. Place second brace on opposite side as shown. Ensure claws are locked into position. To unlock press trigger and lift.



**9** Attach one stabiliser to each corner of the tower. Loosen clamp and place around vertical tube, tighten using handle. Refer to Stabiliser Section for positioning diagrams. To attach one stabiliser to each corner of the tower loosen clamp and place around vertical tube, tighten using handle.



# Assembly

During assembly a Temporary Guardrail will be employed.

**10** Position Trapdoor Deck on 8th rung. Ensure windlocks on both sides are locked (see Fig 3). Ascend the tower through the trap door of the platform.

**All components must be passed through the trap door or be lifted well within the footprint of the tower.**

Temporary Horizontal Guardrails must be positioned 4 rungs up from the platform during building.



# Assembly

## Stage 3

**11** Fit temporary Guardrails. Locate Guardrail Frames and Guardrails. Ensure the interlock clips are engaged. Bracing pattern should follow a simple zig-zag shape (see insert).

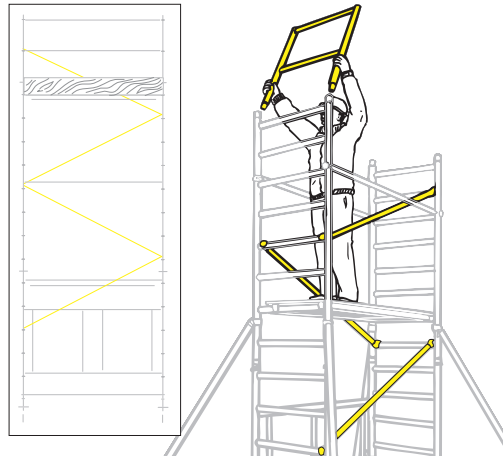

**12** Ensure Intermediate Guardrails are positioned onto the upright above the horizontal tube, with the claws locked outwards as shown. Then move the platform and temporary Guardrails down 2 rungs.



# Assembly

**13** Move other platform to the top rung of the 2m Extension Frame. Ensure all Windlocks are locked.



**14** Position upper Guardrails. Now fit toeboards correctly, ensuring there are no gaps large enough for objects to fall through and that the trap door can open and close with ease. (see Toeboard section).

**Your Tower is now complete and is ready to use.**

For increased heights refer to quantity schedule for additional packs, erect as described in **stage 2**.

To dismantle see **dismantling** on page 16.



## Assembly

### 5.8m Platform Height: Add 2m Extension Pack And Use Medium (SP10) Stabilisers

**15** For the 5.8m height 2 further 8 Rung Frames will be required plus additional Diagonal and Horizontal Braces, and a further Trapdoor Platform. Build as shown in **stages 11 to 14**, taking particular care to ensure that you are fully protected by Guardrails on a Platform during assembly.

**Should the platforms or braces obstruct on any one level, simply re-position one of these components by one rung to suit.**

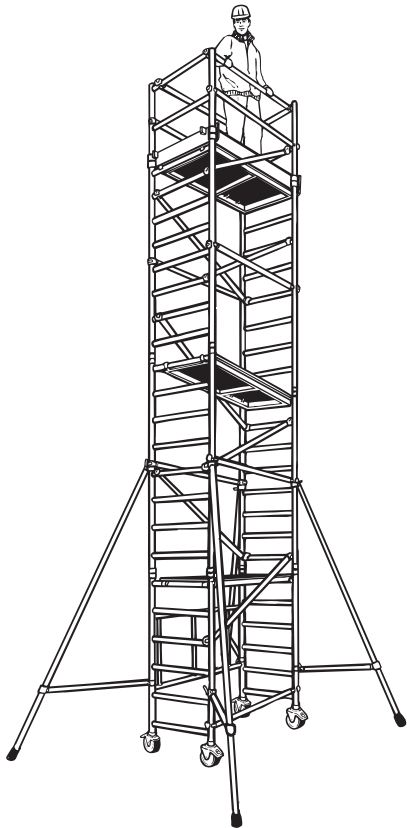

15

## Dismantling

The dismantling procedure should follow steps 1 through to 14 in the reverse order, but taking particular care with the gradual removal of Guardrails and Platforms. You should ensure that you are standing in a safe position and protected by Temporary Guardrailing, ensuring that no Diagonal Braces or Stabilisers are prematurely released.

- 1** Remove Toeboards and upper Guardrails.
- 2** Go down to lower platform, remove upper platform.
- 3** Move lower platform and Guardrails up two rungs, so that you can handle the components above without over-reaching.
- 4** From the upper platform, remove Guardrail Frames and their Guardrails.



- 5** Remove remaining platforms, 8 Rung Frames, upper Guardrails and Diagonals.

16

## Assembly

### Lower Height Setting

Platform Height = 1.7m  
Working Height = 3.7m

### Packs Required

1 × Base Pack  
1 × Guardrail Pack  
2 × Small Stabiliser Packs (if used externally) For internal use stabilisers are not required if horizontal forces are less than 20kg.



### Fitting Toeboards

Start with the End Boards which have red plastic clips. There are two slots depending on which side you position the diagonal brace. Clip into correct slots, as shown, ensuring that no large objects can fall through and that the trap door can open with ease.

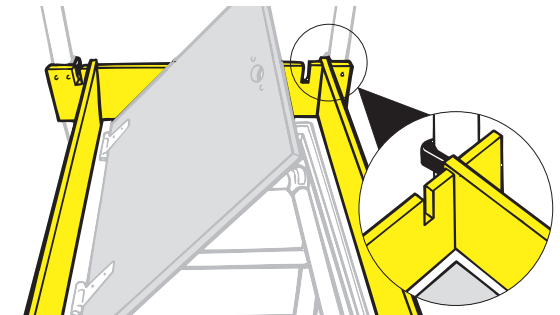

17

# Stabilisers

Attach one stabiliser to each corner of tower at approx. 45 degrees. The bottom clamp should be fitted as low as possible, refer to the diagram below. Ensure that all 4 rubber feet are in contact with the ground and that the clamps are secured.

Position stabilisers as shown in diagrams.

When using the medium stabilisers, always extend the telescopic legs to their maximum position and lock into position with the interlock clip.

When moving tower lock each telescopic leg just clear of the ground, unlock castors ensuring area is firm and clear of all obstructions both on the ground and above. After moving check all castors are firmly on the ground and locked, and that the tower is vertical. Re-position stabilisers as above.

# YOUNGMAN

INNOVATIVE WORK AT HEIGHT SOLUTIONS

## Small Stabiliser

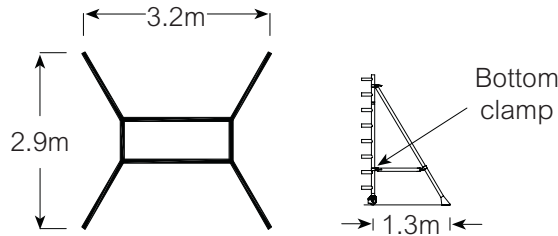

## Medium Stabiliser

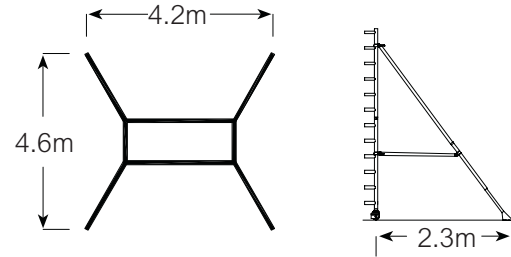

For further information about this product or any other products and services, please contact :

**Youngman Group Ltd**  
The Causeway, Maldon,  
Essex, CM9 4LJ,  
United Kingdom

**t** +44 (0)1621 745900  
**f** +44 (0)1621 859845  
**e** sales@youngmangroup.com

[youngmangroup.com](http://youngmangroup.com)